

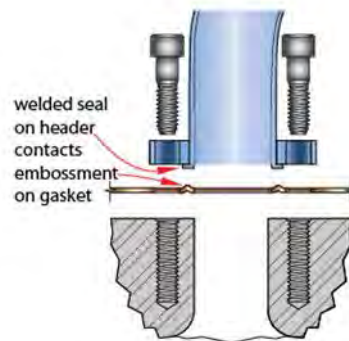

PRO HEAD & EXHAUST GASKETS COPPER

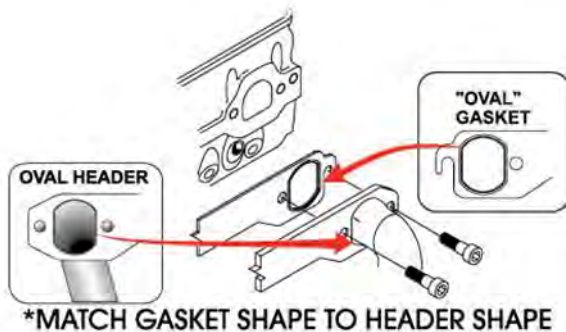

Installation Instructions

Note: Pro Copper exhaust gaskets will provide years of leak free performance if these simple steps are followed. However, mis-matched gaskets (such as a D-port gasket on an oval header) will cause leaks because the embossment is not in complete contact with the raised weld bead of the header.

Steps:

1. Determine the shape & size of the header or manifold opening. The shape of the cylinder head exhaust port is of secondary concern if there is adequate sealing surface for the header opening.
2. Select the SCE Pro Copper exhaust gasket which most closely matches the shape and size of the header or manifold opening (see illustration above). Ensure the embossed sealing bead aligns with the raised weld bead of the header sealing surface when assembled.
3. Clean and lubricate the threads in the cylinder head so full clamping is achieved when bolts are torqued. Once the gasket is fully seated the bolts will not loosen because the gasket is solid metal and will not shrink from repeated heat cycling.
4. Install gaskets and torque to specification. Proper torque for new lubricated 3/8" x 16 grade 5 bolts is 23 to 31 ft lbs.

Extreme heat applications such as towing may cause the gasket embossment to relax or flatten slightly as indicated by a "ticking" sound at idle. Do not discard the gasket; simply re-torque the bolts, 1 re-torque is usually sufficient for permanent sealing.